

COULOSCOPE® CMS2 and COULOSCOPE® CMS2 STEP

Measurement of coating thicknesses and electrochemical potentials according to the coulometric method



Coulometry is an electrochemical analysis method that is simple and easy to execute and can be applied in order to determine the thickness of metal coatings. While primarily used for checking the quality of electroplated coatings, this method is also suitable for monitoring the thickness of the remaining pure tin on printed circuit boards.



Measuring the thickness of remaining tin on a printed circuit board using the COULOSCOPE CMS2 and support stand V18

COULOSCOPE® CMS2

The CMS2 measures the thickness of virtually any metallic coating, including multi-layer, on any substrate material; it works according to the coulometric method by anodic dissolution (DIN EN ISO 2177). The simple handling and menu-supported operator guidance makes the CMS2 the ideal solution for both production monitoring in the electroplating industry and incoming inspection on finished parts. The device comes equipped with nearly 100 predefined measuring applications for different coating systems (e.g. zinc on iron, nickel on brass), as well as various de-plating speeds (e.g. 1, 2, 5, and 10 $\mu\text{m}/\text{min}$). These can also be combined for measuring multi-layer systems.

COULOSCOPE® CMS2 STEP

The CMS2 STEP features the additional STEP Test (Simultaneous Thickness and Electrochemical Potential determination) function. It is used for standardised STEP Test measurements of individual coating thicknesses and differences in potential (according to ASTM B764-94 and DIN 50022) in the quality control of multiplex nickel coating systems. The coating thickness measurement is carried out according to the coulometric method, while the potential profile is captured using a silver reference electrode coated with AgCl.

Features of the COULOSCOPE® CMS2

- Large, high-resolution colour display
- Simple instrument operation and graphically-supported user guidance
- Partially-automated measurement with support stand V18
- Simple selection of de-plating speed (0.1 – 50 $\mu\text{m}/\text{min}$) and de-plating area (0.6 – 3.2 mm \varnothing)
- Graphic display of the voltage profile in the measuring cell
- Graphic and statistical analysis options
- Various languages and measurement units to choose from

Special features of the COULOSCOPE® CMS2 STEP

- Simultaneous measurement of coating thickness and differences in potential
- Simple conditioning of the silver reference electrode
- Adjustable de-plating current



The widely-applicable standard support stand V18 and specialised support stand V27 for measuring the thickness of coatings on wires

System overview

A functional measuring station comprises a COULOSCOPE® CMS2 or CMS2 STEP and a support stand with a measuring cell (e.g. STEP measuring cell). Various stand designs, including measuring cells, are available to suit a range of applications.

Optional accessories

The extensive assortment of available accessories facilitates effective work practices, ensures safe storage and provides aids for fastening specimens.



Vice for fastening specimens, also suitable for mounting onto the clamping plate of both support stands V18 and V24



COULOSCOPE CMS2 STEP workstation: Support stand V18 with ball-jointed sample support and swivelling clamping plate. The measuring cell storage rack for stowing the measuring cell can also hold up to three 100-ml laboratory bottles

Calibration

The calibration process establishes a correction factor that takes such variables into account as departures in the actual diameter of plastic seals from the reference value, deviations in alloy composition and fluctuations in the density of the coating material.

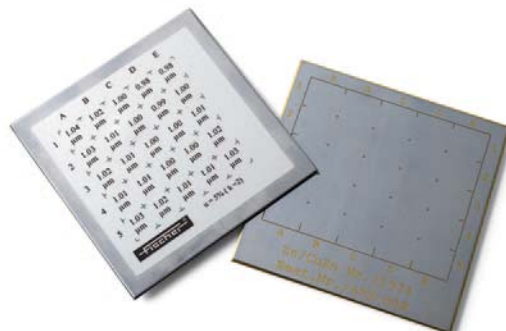

Standards for calibrating the measurement system with 5 x 5 individually-measured test areas

Applications for the COULOSCOPE® CMS2



One of the simplest methods for measuring coating thickness, the coulometric method can be employed for a wide variety of coating-substrate combinations. Especially with multi-layer coatings, it offers a cost-effective alternative to the X-ray fluorescence method whenever a destructive measurement method can be tolerated.

Application

The robust and user-friendly **COULOSCOPE CMS2** is suitable for both production monitoring in the electroplating industry and incoming inspection on finished parts.

Many common single and duplex coatings, such as Zn on iron or Sn/Ni on copper, can be measured quickly and simply using the CMS2. The method provides for accurate measurements of practically any metal coating. In the thickness range of 0.05 - 50 µm, no pre-settings are required for many materials; substrate composition and geometry are also irrelevant to the measuring process.

One of the most frequent applications is the measurement of the remaining pure tin on printed circuit boards in order to ensure solderability. Multi-layer coatings such as Cr/Ni/Cu on iron or plastic (ABS) substrates, often found in high-quality bathroom fittings for example, can also be measured with this method.

Application examples for the COULOSCOPE CMS2: electroplated fasteners, testing the remaining pure tin content on printed circuit boards, chrome-plated bathroom fittings

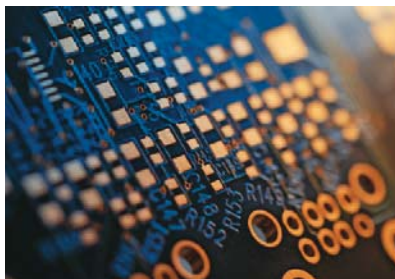

Coulometric coating thickness measurement according to DIN EN ISO 2177

Test method

The COULOSCOPE instrument series operates according to the coulometric test method as per DIN EN ISO 2177. This involves dissolving a metal coating off of its metallic or non-metallic substrate by means of an electrolyte under controlled electric current, i.e. reversing the electroplating process (de-plating). The current required for de-plating is directly proportional to the mass of the metal to be removed. A clear correlation between the de-plating time and the coating thickness arises when the test current and area are both kept constant.

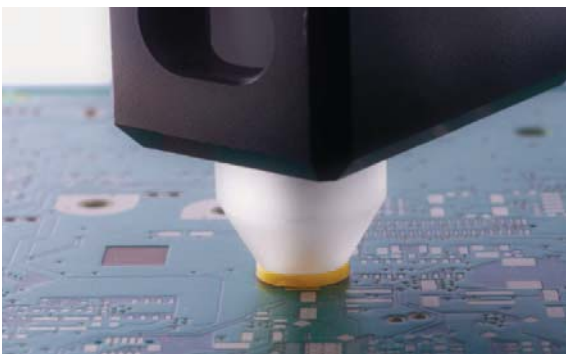

Measuring the thickness of remaining tin on a printed circuit board

The following formula applies for determining coating thickness via the coulometric de-plating process:

$$d = \frac{e\ddot{A} \cdot I \cdot \gamma \cdot t}{A \cdot \rho}$$

- d : Coating thickness [μm]
- $e\ddot{A}$: Electrochemical equivalent [g/As]
- I : De-plating current [A]
- γ : Current efficiency
- t : De-plating time [s]
- A : De-plating area [cm^2]
- ρ : Density of the de-plated coating material [g/cm^3]

De-plating takes place in a measuring cell – a kind of miniature electrolytic bath. The measuring area is defined by a plastic gasket attached to the measuring cell. The electrolytes used are formulated for the various coating materials such that de-plating does not start until current flows. The de-plating process is initiated by the instrument's electronics. A pump circulates the liquid within the measuring cell, continually refreshing the electrolyte in contact with the de-plating area, thereby ensuring uniform de-plating. Depending on the size of the area to be measured, gaskets with various diameters are available for the measuring cell.

Schematic representation

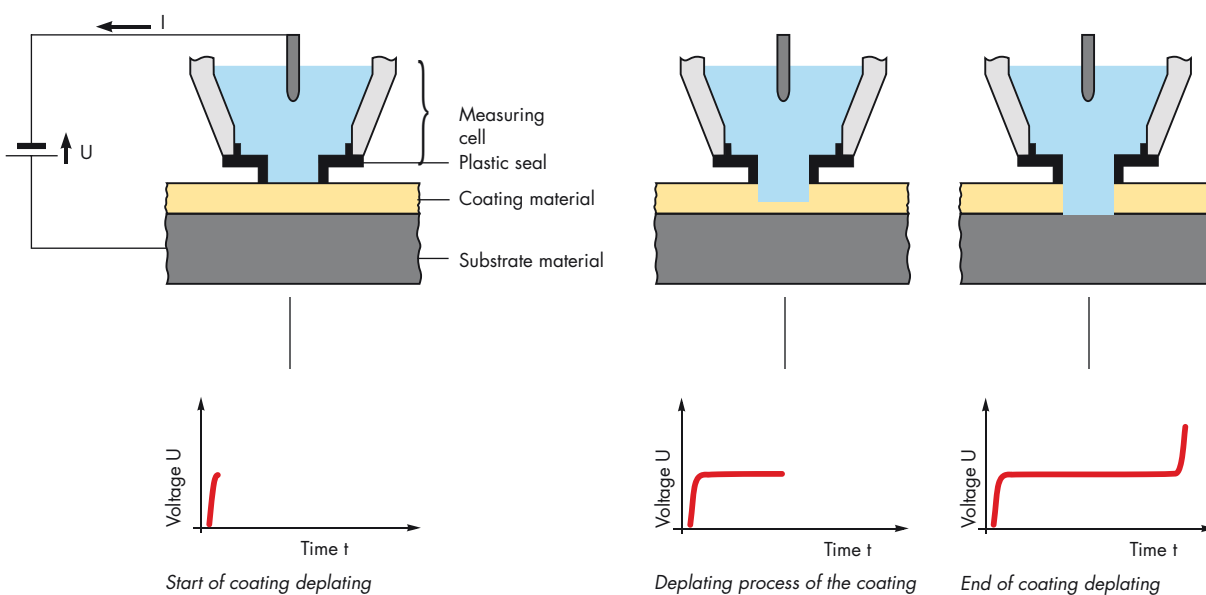

Applications for COULOSCOPE® CMS2 STEP

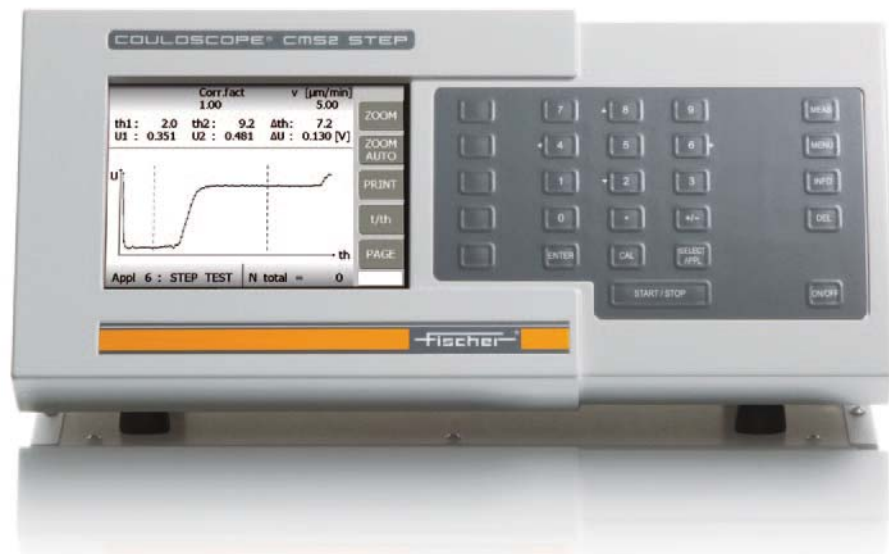

The STEP Test is used to measure simultaneously the differences in potential and the thicknesses of multiplex nickel coatings, allowing for assessment of their corrosion behaviour. This method has established itself as a standard for this special area of application.

Application

Quality control of multiplex nickel coatings calls for instruments that can check both the thickness and the electrochemical potential immediately after the coating procedure. Developed specifically for this purpose, the COULOSCOPE CMS2 STEP measurement system is suited

to the harsh environment typical of electroplating plants; it is simple to operate, and handling the reference electrode is straightforward. Electrolytic nickel-plating is commonly used for decorative corrosion protection and for improving such mechanical surface properties as hardness.

Especially in the automotive industry, nickel-plated components must meet stringent specifications with regard to corrosion behaviour; single-layer nickel coatings are not suitable for this purpose. As a result, complex coating systems consisting of two, three or even four different nickel layers, including additional coatings of chromium or copper, are being developed.



Typical application for the CMS2 STEP: chrome-plated trim elements in automotive manufacturing, based on multiplex nickel coatings

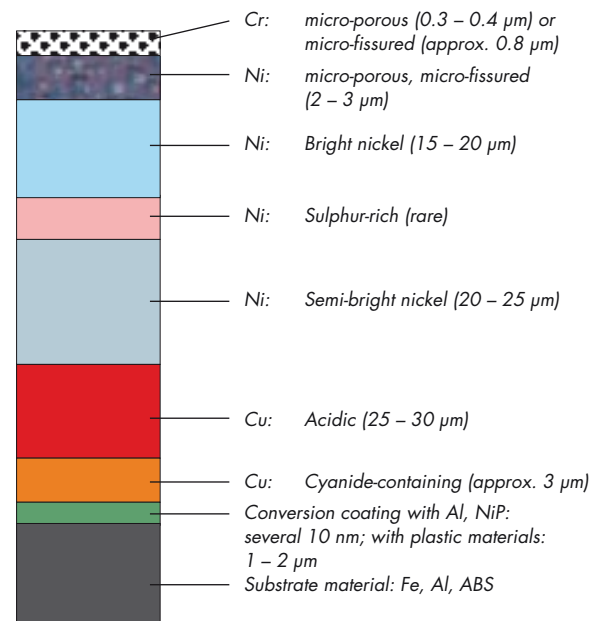

Basic structure of a coating system with 4 nickel coatings

STEP Test measurement according to ASTM B764 – 94 and DIN EN ISO 2177

Test method

The STEP Test (Simultaneous Thickness and Electrochemical Potential determination) is a long-standardised method for simultaneously determining individual coating thicknesses and the differences in electrochemical potential between the individual layers of a multiplex nickel coating system. The coating thickness measurement is carried out according to the coulometric method, while the potential profile is captured using a silver reference electrode coated with AgCl. The potential profile is shown on the display; individual coating thicknesses and differences in potential can be viewed by positioning the cursor correspondingly on the plot.

To obtain comparable results with this method, the reference electrode must always be kept the same distance from the specimen; therefore, a special measuring cell is

utilised. The silver reference electrode is a cone-shaped ring that forms the lower housing component of the measuring cell, further requiring only the obligatory gasket. This measuring cell design ensures a consistently uniform distance between the reference electrode and the specimen.



STEP Test measuring cell placed on a specimen

Schematic representation

